

Fixed flange bearings with 2 mounting holes: EFOM



- iglidur® W300 extremely wear-resistant spherical ball
- Easy installation
- Compensation of misalignment errors
- Absolute corrosion resistance
- Lightweight
- Maintenance-free dry operation



Online service life calculation
▶ www.igus.eu/igubal-expert

Technical data

Part No.	Max. permissible axial load		Max. permissible radial load		Max. tightening torque Holes	Weight [g]
	Short-term	Long-term	Short-term	Long-term		
	[N]	[N]	[N]	[N]	[Nm]	
EFOM-04	400	200	750	375	0.6	1.9
EFOM-05	400	200	750	375	0.6	2.3
EFOM-06	500	250	800	400	0.6	1.8
EFOM-08	700	350	1,100	550	1.3	4.1
EFOM-10	850	425	2,000	1,000	2.5	6.8
EFOM-12	1,100	550	2,200	1,100	2.5	8.9
EFOM-15	1,300	650	2,400	1,200	4.5	15.0
EFOM-16	1,400	700	2,800	1,400	4.5	17.7
EFOM-17	1,800	900	3,200	1,600	4.5	24.9
EFOM-20	1,800	900	5,500	2,750	10.5	32.8
EFOM-25	3,000	1,500	6,000	3,000	10.5	58.5
EFOM-30	3,500	1,750	6,500	3,250	21.5	78.9

Alternative spherical ball materials ▶ Page 993



J4VEM:
Clearance-free,
pre-loaded



JEM:
low moisture
absorption



REM:
Low-cost



J4EM:
Low-cost and low
moisture absorption

Fixed flange bearings with 2 mounting holes: EFOM

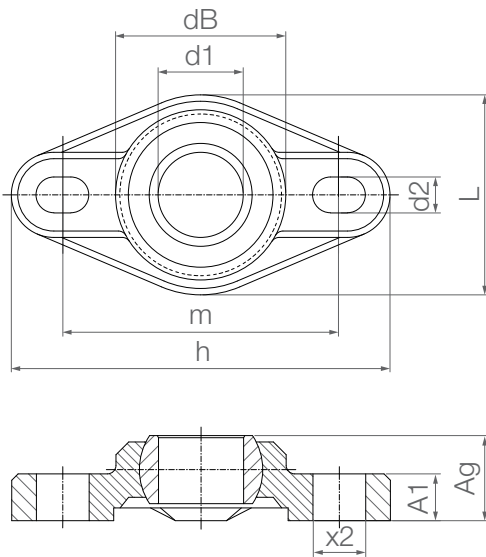

Order key

Type

Size

E F O M-04



Spherical ball material

Blank : iglidur® W300

J4V : iglidur® J4V

R : iglidur® R

J : iglidur® J

J4 : iglidur® J4



Material:

Housing: igumid® G ► Page 1190

Spherical ball: iglidur® W300 ► Page 175

Combination with xiros® ball bearings ► Page 1089



Imperial dimensions available

► Page 1158

Dimensions [mm]

Part No.	d1 E10	dB	h Length	L Width	m Hole pitch ±0.1	A1 Height of plate +1.0	Ag Total height	d2 Elongated hole	x2	Max. pivot angle
EFOM-04	4	14.0	33.8	16.0	24.0	4.5	8.0	3.2	5.0	28°
EFOM-05	5	14.0	33.8	16.0	24.0	4.5	8.5	3.2	5.0	29°
EFOM-06	6	14.0	33.8	16.0	24.0	4.5	8.5	3.2	5.0	25°
EFOM-08	8	18.0	44.2	22.0	31.0	5.5	10.5	4.3	6.5	25°
EFOM-10	10	22.0	52.0	26.0	36.0	6.5	12.0	5.3	8.0	25°
EFOM-12	12	25.0	56.7	31.0	41.0	7.0	13.0	5.3	8.0	21°
EFOM-15	15	29.8	68.6	36.0	50.0	8.5	15.5	6.4	10.0	20°
EFOM-16	16	32.0	72.6	38.0	53.0	10.0	17.5	6.4	10.1	27°
EFOM-17	17	34.8	74.6	41.0	55.0	10.0	18.0	6.4	10.2	21°
EFOM-20	20	40.0	89.0	47.0	65.0	11.0	20.0	8.4	12.5	19°
EFOM-25	25	48.5	101.0	58.5	75.0	14.0	25.0	8.4	12.6	15°
EFOM-30	30	55.0	118.0	65.0	87.5	15.0	26.0	10.5	16.0	14°

Standard tolerances:

from 0.5 to 6mm: ±0.1mm

from 6 to 30mm: ±0.2mm

from 30 to 120mm: ±0.3mm